

STANDARD SPECIFICATIONS
1. ENGINE

- Diesel engine
- 4 strokes-cycle
- Water-cooled
- 12V Electrical system
- Radiator with blowing fan
- Water separator decanting filter (visible level)
- Mechanical governor
- Dry air cleaner
- Hot components and radiator guards
- Mobile components guards

2. Electrical system

- Control and power electric panel, with measurements devices and controller (according to necessity and configuration)
- Earth leakage protection adjustable (time & sensibility) standard
- Battery charger 3 poles (standard on automatic control panels)
- Pre-heating resistance (standard on automatic control panels) / water jacket heater
- Battery charge alternator with ground connection
- Starting battery/ies installed and connected to the engine (supports included)
- Ground connection electrical installation with connection ready for ground pike (not supplied)Optional :
- Battery isolator switch - DSE Battery charger

3. Open set version

- Emergency stop button
- Steel made chassis
- Antivibration shock absorber
- Chassis with integrated fuel tank
- Fuel level sensor
- Drain cap fuel tank
- Steel made residential silencer -15db(A) attenuation

4. Optional

- Fuel transfer pump
- Steel made residential silencer -35db(A) attenuation.

5. CONTROL PANEL

Make	Deep Sea
Model	DSE6110/20

The DSE6110 is an Auto Start Control Module and The DSE6120 is an auto mains(utility) Failure Control Module for single gen-set applications. Both modules have been designed to work with electronic engines providing advance engine monitoring and protection features.

- Transfer between mains(utility) and generator power (DSE6120 only)
- Generator frequency
- Underspeed, Overspeed
- Generator volts (L-L, L-N)
- Generator current
- Engine oil pressure
- Engine coolant temperature
- Fuel level (Warning or shutdown)
- Hours run counter
- Battery volts
- Fail to start/stop
- Emergency stop
- Failed to reach loading voltage/frequency
- Charge fail
- Loss of magnetic pick-up signal
- Low DC voltage
- CAN diagnostics and CAN fail/error

Engine Specifications 1.500 r.p.m.

Manufacturer	YANMAR
Engine Model	4TNV106 T GGE
Engine Type	Diesel 4 strokes-cycle
Injection Type	Direct
Aspiration Type	Natural
Cylinders Arrangement	4 - L
Bore and Stroke mm	106 x 125
Displacement Liters	4.412
Cooling System	Coolant
Lube Oil Specifications	SAE 3 class 10W30 / API grade CD,CF
Compression Ratio	18
Fuel Consumption StandBy L/h	13.6
Fuel Consumption 100% PRP L/h	12.2
Fuel Consumption 75 % PRP L/h	8.7
Fuel Consumption 50 % PRP L/h	5.5
Lube Oil Consumption Full Load g/kwh	0.27
Total Oil Capacity L	14
Total Coolant Capacity L	6
Governor	Mechanical
Air Filter	Dry
Inner diameter exhaust pipe mm	45
Intake Air Flow m³/h	194.42
Cooling Air Flow m³/h	0.979
Alternator fan air flow m³/s	0.09
Fuel Tank volume L	120
Starting motor KW	3.0
Starting motor CV	3.13
Recommended Battery Capacity Ah	75
Auxiliary voltage Vcc	12
Maximum Exhaust Temperature °C	557
Exhaust Gas Flow m³/min	10.45

DIMENSIONS AND WEIGHT*

Lengthmm	Widthmm	Heightmm	Weight* kg (dry)
2280	980	1300	1064

* For skid mounted genset without enclosure wet weight= with lube oil and coolant

Output Ratings	Prime	Standby
380-415 V, 3 ph, 50 Hz, 1500 rpm	56.18 KVA	61.79 KVA
	44.94 KW	49.44 KW
480 V, 3 ph, 60 Hz, 1800 rpm	56.50 KVA	62.15 KVA
	45.20 KW	49.72 KW

Applicable Voltages: 220/127 V at 60 Hz only (Consult your dealer for more details)
 Ratings at 0.8 Power Factor

60 KVA

POWERED
BY:

ALTERNATOR DATA

Make	Leroy Somer TAL
Model	TAL 042 H / TAL A42 H
KVA	60
KW	48
No. of bearings	1
Insulation class	H
Total Harmonic Content	in linear load <5% , at no load <2%
Winding Leads	6
Ingress Protection	IP23
Excitation System	self excitation
Winding Pitch	2/3
AVR Model	R120
Overspeed	2250 rpm
Voltage Regulation	± 1.0 %
Short Circuit Capacity	-

The image shown above might not be the final product

STANDARD SPECIFICATIONS

6. FUEL SYSTEM

On Generating Sets up to 2000 KVA, the base frame design can be incorporated with an integral fuel tank with a capacity of approx. 8 hours running at Full Load. The tank is supplied complete with fill cap breather fuel feed and return lines to the Engine and drain plug.

7. ALTERNATOR

7.1 INSULATION SYSTEM

- The insulation system is Class H.
- All windings are impregnated in either a triple dipthermosetting liquid, oil and acid resisting polyester varnish or vacuum pressure impregnated with a special polyester resin.

- Heavy coat of antitracking varnish additional protection against moisture.

7.2 AUTOMATIC VOLTAGE REGULATOR (AVR)

The fully sealed Automatic Voltage Regulator maintains the Voltage Regulation at $\pm 1\%$. Nominal adjustment by means of a trim pot incorporated on the AVR.

7.3 MOTOR STARTING an overload capacity equivalent to 300% of the Full Load impedance at zero Power Factor can be sustained for 10 seconds.

8. MOUNTING ARRANGEMENT

8.1 BASE FRAME

The complete Generating Set is mounted as a whole on a heavy duty fabricated steel Baseframe.

8.2 COUPLING The Engine and Alternator are directly coupled by means of an SAE flange. The Engine flywheel is flexibly coupled to the Alternator rotor.

8.3 ANTI-VIBRATION MOUNTING PADS anti-Vibration pads are affixed between the Engine / Alternator feet and the Baseframe thus ensuring complete vibration isolation of the rotating assembly. The Fan & Fan Drive along with the Battery Charging

8.4 SAFETY GUARDS The Fan & Fan Drive along with the Battery Charging Alternator are Safety Guard protected for personal protection.

9. FACTORY TESTS

- The Generating set is load tested before dispatch
- All protective devices control functions and site load conditions are simulated. The generator and it's systems are checked before dispatch.

10. EQUIPMENT FINISHING all mild steel components are fully degreased and painted with powder coated paint to ensure maximum scuff resistance and durability.

RATINGS DEFINITION

Prime Power

These ratings are applicable for supplying continuous electrical power (at variable load) in lieu of commercially purchased power. 10% overload power is available for 1 hour in 12 hours continuous operation.

Standby Power

These ratings are applicable for supplying continuous electrical power (at variable load) in the event of a utility power failure. No overload is permitted on these ratings.

STANDARD REFERENCE CONDITIONS

Output ratings are presented at 25°C air inlet temperature, barometric pressure 100 kPa, relative humidity 30%. This generating set is designed to operate at high ambient temperatures (up to 55°C), humidity (up to 99%) and altitudes. De-ration may apply, please consult your dealer for specific site ratings.

STAUNCH Generators are assembled Some of the specifications are not standard on all Genset models. in facilities certified to ISO 9001 All information in this document is substantially correct at time of printing and may be altered subsequently.

Generating Set pictured may include optional accessories.

11. DOCUMENTATIONS a set of Operation & Maintenance manual, Circuit wiring diagrams and Commissioning / Fault Finding instruction leaflets accompany the Generator.

12. QUALITY STANDARDS The equipment meets the following standards: BS4999, BS5000, BS5514 IEC 60034, VDE0530, NEMA MG 1.22 and ISO 8528.

13. WARRANTY All of the Generating Sets are covered under a warranty policy for a period of 12 months. Warranty of the equipment is in line with manufacturers warranty terms & conditions.

(check warranty statement for more details, as it may vary for different countries) In line with continuous product development, we reserve the right to change specifications without notice.

For further information on all of the standard and optional features accompanying this product please contact your local dealer or visit:

WWW.STAUNCHMACHINERY.COM

AVAILABLE OPTIONS & ACCESSORIES

We offer a range of optional features and accessories to tailor our generating sets to meet your power needs.

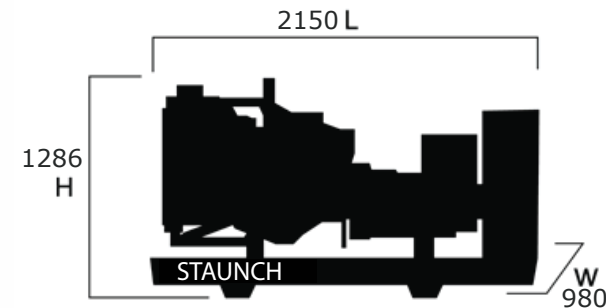
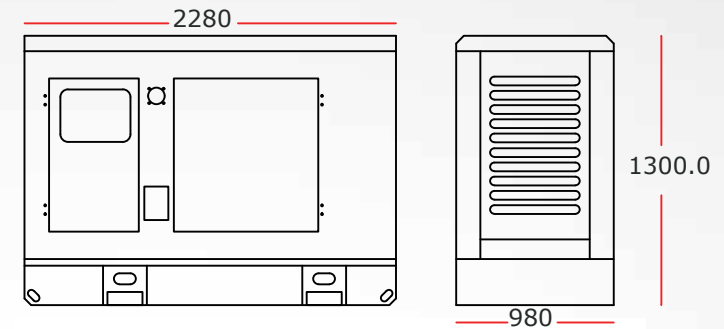

ACCESSORIES

- switches
- Load banks
- Auxiliary fuel tanks
- Manual & automatic
- Genuine spare partstransfer

OPTIONS

- Water jacket heater
- A variety of generating set
- Additional protection alarms
- Water fuel seperator control and synchronizing and shutdowns
- panels
- Battery charger