

## STANDARD SPECIFICATIONS

### 1. ENGINE

Perkins four stroke heavy duty high performance industrial type diesel engine.

### 2. ENGINE FILTRATION SYSTEM

- Cartridge type dry air filters.
- Cartridge type fuel filters.
- Full flow lube oil filters.

All filters have replaceable elements.

### 3. COOLING RADIATOR

Radiator and cooling fan, complete with safety guards, designed to cool the engine at high ambient temperatures (consult your dealer for de-rating factors).

### 4. EXHAUST SYSTEM

Silencer noise reduction level	20 (dB)
Maximum allowable back pressure	10.2 (kPa)

### 5. CIRCUIT BREAKER TYPE

3 pole MCB/MCCB (supplied disconnected and without cables)

### CONTROL PANEL

Make	Deep Sea
Model	DSE4510/20

*The DSE4510 is an Auto Start Control Module and The DSE4520 Auto Mains(Utility) Failure control Module are suitable for a wide variety of single gen-set applications*

- Alternator frequency & CAN speed sensing in one variant
- Largest back-lit icon display in its class
- Fully configurable via the fascia or PC using USB
- 3 Phase generator sensing
- 3 Phase mains(utility) sensing(DSE4520 only)
- Generator/load power monitoring(KW,KV,KVAR,PF)
- Accumulated power monitoring(KW h, KVA h, KVAR h)
- Generator overload protection(KW)
- Generator/load current monitoring and protection
- Fuel and start outputs(configurable when using CAN)
- Configurable staged loading outputs
- Engine speed protection
- Engine pre-heat
- Engine run-time scheduler
- Battery voltage monitoring
- Comprehensive warning, electrical trip or shutdown protection upon fault condition

## ENGINE / TECHNICAL DATA

Engine Make		Perkins			
Engine Model		404D-22G1			
Governing class		ISO 8528			
Number of Cylinders		4			
Cylinder Arrangement		Vertical in line			
Bore and Stroke mm		84 x 100			
Displacement / Cubic Capacity litres		2.216			
Induction System		Naturally Aspirated			
Cycle		4 stroke			
Combustion System		Indirect Injection			
Compression Ratio		23.3:1			
Rotation		Anti-clockwise, viewed on flywheel			
Cooling System		Water - cooled 50Hz & 1500rpm / 60Hz & 1800rpm			
Frequency and Engine Speed					
		Prime	Standby	Prime	Standby
Gross Engine Power kW (hp)		18.7 (25.0)	20.6 (28.0)	-	-
Fuel Consumption @ 50% load L/hr		2.9	-	-	-
@ 75% load L/hr		4.0	-	-	-
@ 100% load L/hr		5.3	6.1	-	-
Total Lubrication System Capacity litres		10.6	10.6	-	-
Total Coolant Capacity (inc. radiator) litres		7.0	7.0	-	-
Exhaust Temperature: °C		445	505	-	-
Radiator Cooling Air Flow (Min): m <sup>3</sup> /sec		0.55	0.58	-	-
Combustion Air Flow: m <sup>3</sup> /min		1.5	1.5	-	-
Exhaust Gas Flow: m <sup>3</sup> /min		3.6	3.9	-	-
Fuel Tank Capacity: litres		40	40	-	-

### DIMENSIONS AND WEIGHT\*

Length mm	Width mm	Height mm	Weight* kg (wet)
1800	750	1310	796

\* For skid mounted genset without enclosure wet weight = with lube oil and coolant

Output Ratings	Prime	Standby
380-415 V, 3 ph, 50 Hz, 1500 rpm	18.30 KVA	20.13 KVA
	14.64 KW	16.10 KW
480 V, 3 ph, 60 Hz, 1800 rpm	19.62 KVA	21.85 KVA
	15.70 KW	17.27 KW

Applicable Voltages: 220/127 V at 60 Hz only (Consult your dealer for more details)

Ratings at 0.8 Power Factor

# 20 KVA

POWERED  
BY:



### ALTERNATOR DATA

Make	Leroy Somer TAL
Model	TAL 040 F / TAL A40 F
KVA	20
KW	16
No. of bearings	1
Insulation class	H
Total Harmonic Content	in linear load <5% , at no load <3.5%
Winding Leads	6
Ingress Protection	IP23
Excitation System	SHUNT
Winding Pitch	2/3
AVR Model	R120
Overspeed	2250 mn <sup>-1</sup>
Voltage Regulation	± 1.0 %
Short Circuit Capacity	-

## STANDARD SPECIFICATIONS

### 6. FUEL SYSTEM

On Generating Sets up to 2000 KVA, the base frame design can be incorporated with an integral fuel tank with a capacity of approx. 8 hours running at Full Load. The tank is supplied complete with fill cap breather fuel feed and return lines to the Engine and drain plug.

### 7. ALTERNATOR

#### 7.1 INSULATION SYSTEM

- The insulation system is Class H.
- All windings are impregnated in either a triple dipthermosetting liquid, oil and acid resisting polyester varnish or vacuum pressure impregnated with a special polyester resin.

- Heavy coat of antitracking varnish additional protection against moisture.

#### 7.2 AUTOMATIC VOLTAGE REGULATOR (AVR)

The fully sealed Automatic Voltage Regulator maintains the Voltage Regulation at  $\pm 0.5\%$ . Nominal adjustment by means of a trim pot incorporated on the AVR.

**7.3 MOTOR STARTING** an overload capacity equivalent to 300% of the Full Load impedance at zero Power Factor can be sustained for 10 seconds.

### 8. MOUNTING ARRANGEMENT

#### 8.1 BASE FRAME

The complete Generating Set is mounted as a whole on a heavy duty fabricated steel Baseframe.

**8.2 COUPLING** The Engine and Alternator are directly coupled by means of an SAE flange. The Engine flywheel is flexibly coupled to the Alternator rotor.

**8.3 ANTI-VIBRATION MOUNTING PADS anti-Vibration** pads are affixed between the Engine / Alternator feet and the Baseframe thus ensuring complete vibration isolation of the rotating assembly. The Fan & Fan Drive along with the Battery Charging

**8.4 SAFETY GUARDS** The Fan & Fan Drive along with the Battery Charging Alternator are Safety Guard protected for personal protection.

### 9. FACTORY TESTS

- The Generating set is load tested before dispatch
- All protective devices control functions and site load conditions are simulated. The generator and it's systems are checked before dispatch.

**10. EQUIPMENT FINISHING** all mild steel components are fully degreased and painted with powder coated paint to ensure maximum scuff resistance and durability.

### RATINGS DEFINITION

#### Prime Power

These ratings are applicable for supplying continuous electrical power (at variable load) in lieu of commercially purchased power. 10% overload power is available for 1 hour in 12 hours continuous operation.

#### Standby Power

These ratings are applicable for supplying continuous electrical power (at variable load) in the event of a utility power failure. No overload is permitted on these ratings.

### STANDARD REFERENCE CONDITIONS

Output ratings are presented at 25°C air inlet temperature, barometric pressure 100 kPa, relative humidity 30%. This generating set is designed to operate at high ambient temperatures (up to 55°C), humidity (up to 99%) and altitudes. De-rating may apply, please consult your dealer for specific site ratings.

**STAUNCH** Generators are assembled Some of the specifications are not standard on all Genset models. in facilities certified to ISO 9001 All information in this document is substantially correct at time of printing and may be altered subsequently.

Generating Set pictured may include optional accessories.

**11. DOCUMENTATIONS** a set of Operation & Maintenance manual, Circuit wiring diagrams and Commissioning / Fault Finding instruction leaflets accompany the Generator.

**12. QUALITY STANDARDS** The equipment meets the following standards: BS4999, BS5000, BS5514 IEC 60034, VDE0530, NEMA MG 1.22 and ISO 8528.

**13. WARRANTY** All of the Generating Sets are covered under a warranty policy for a period of 12 months. Warranty of the equipment is in line with manufacturers warranty terms & conditions.

(check warranty statement for more details, as it may vary for different countries) In line with continuous product development, we reserve the right to change specifications without notice.

**For further information on all of the standard and optional features accompanying this product please contact your local dealer or visit:**

[WWW.STAUNCHMACHINERY.COM](http://WWW.STAUNCHMACHINERY.COM)

### AVAILABLE OPTIONS & ACCESSORIES

We offer a range of optional features and accessories to tailor our generating sets to meet your power needs.

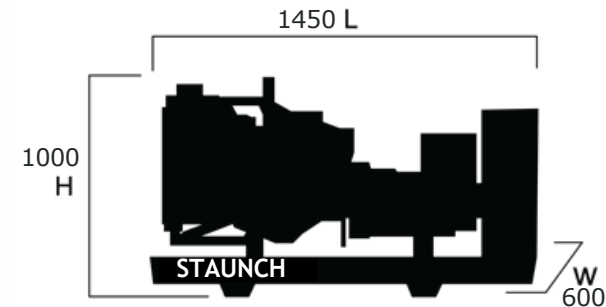
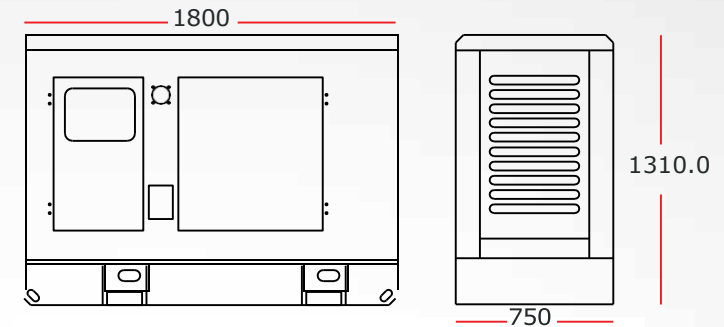

### ACCESSORIES

- switches
- Load banks
- Auxiliary fuel tanks
- Manual & automatic
- Genuine spare partstransfer

### OPTIONS

- Water jacket heater
- A variety of generating set
- Additional protection alarms
- Water fuel seperator control and synchronizing and shutdowns
- panels
- Battery charger